

PROPOSED PLAN

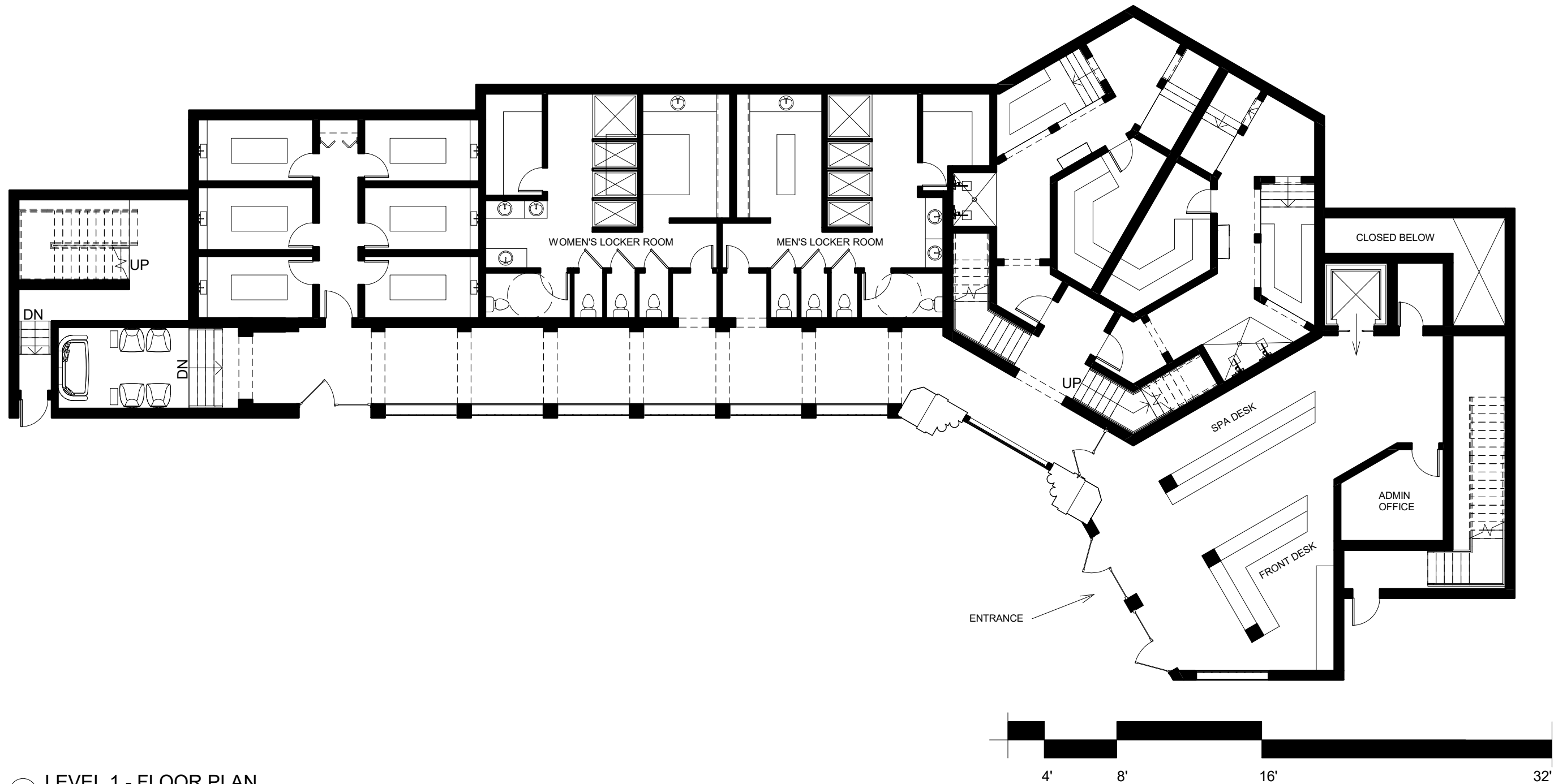

NEW FLOOR PLAN



① LEVEL 1 - FLOOR PLAN
1" = 12'-0"



NEW FLOOR PLAN

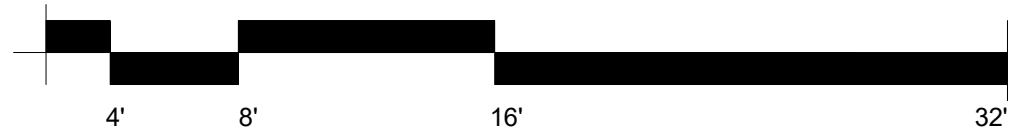
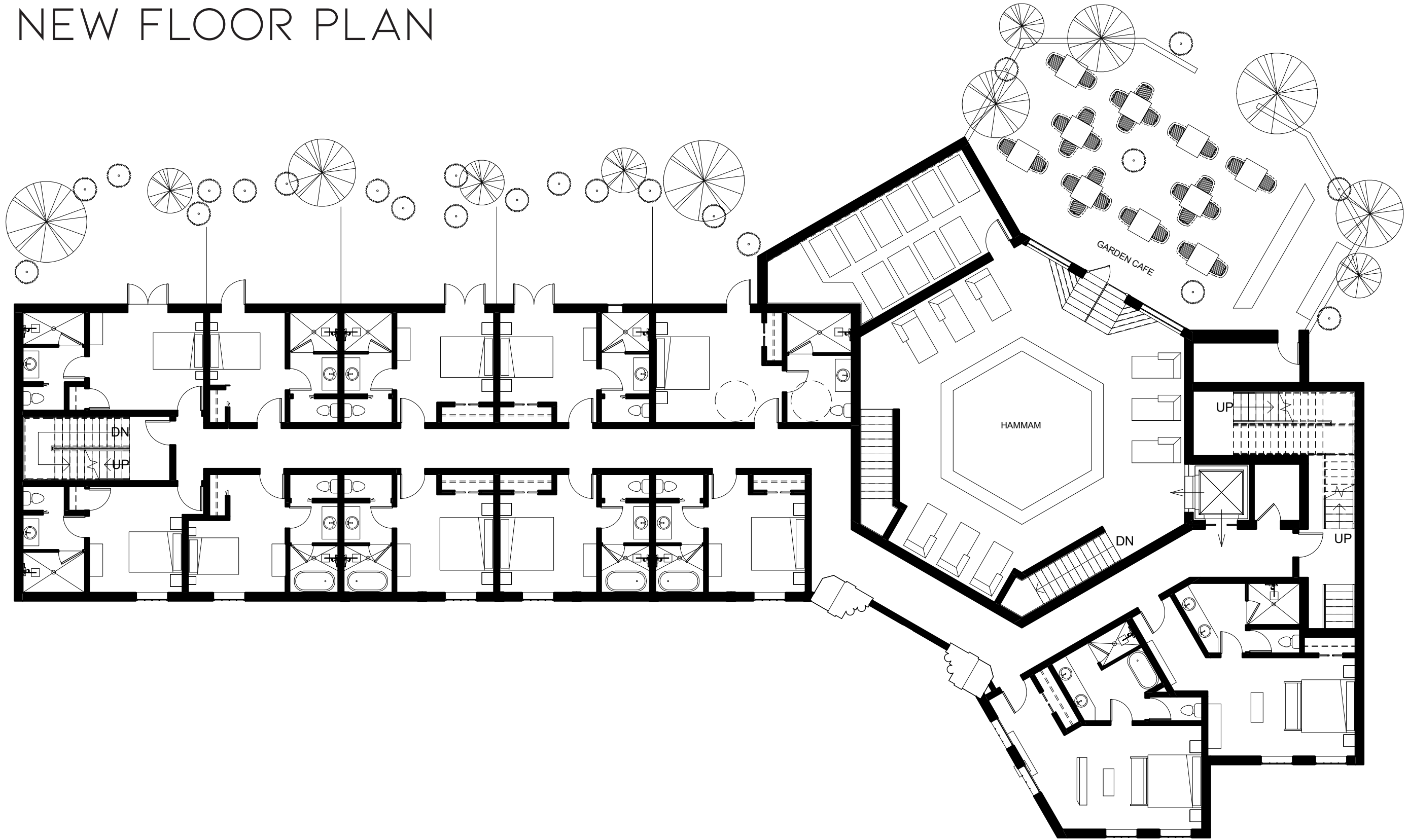

① LEVEL 2- FLOOR PLAN
1" = 12'-0"

NEW FLOOR PLAN

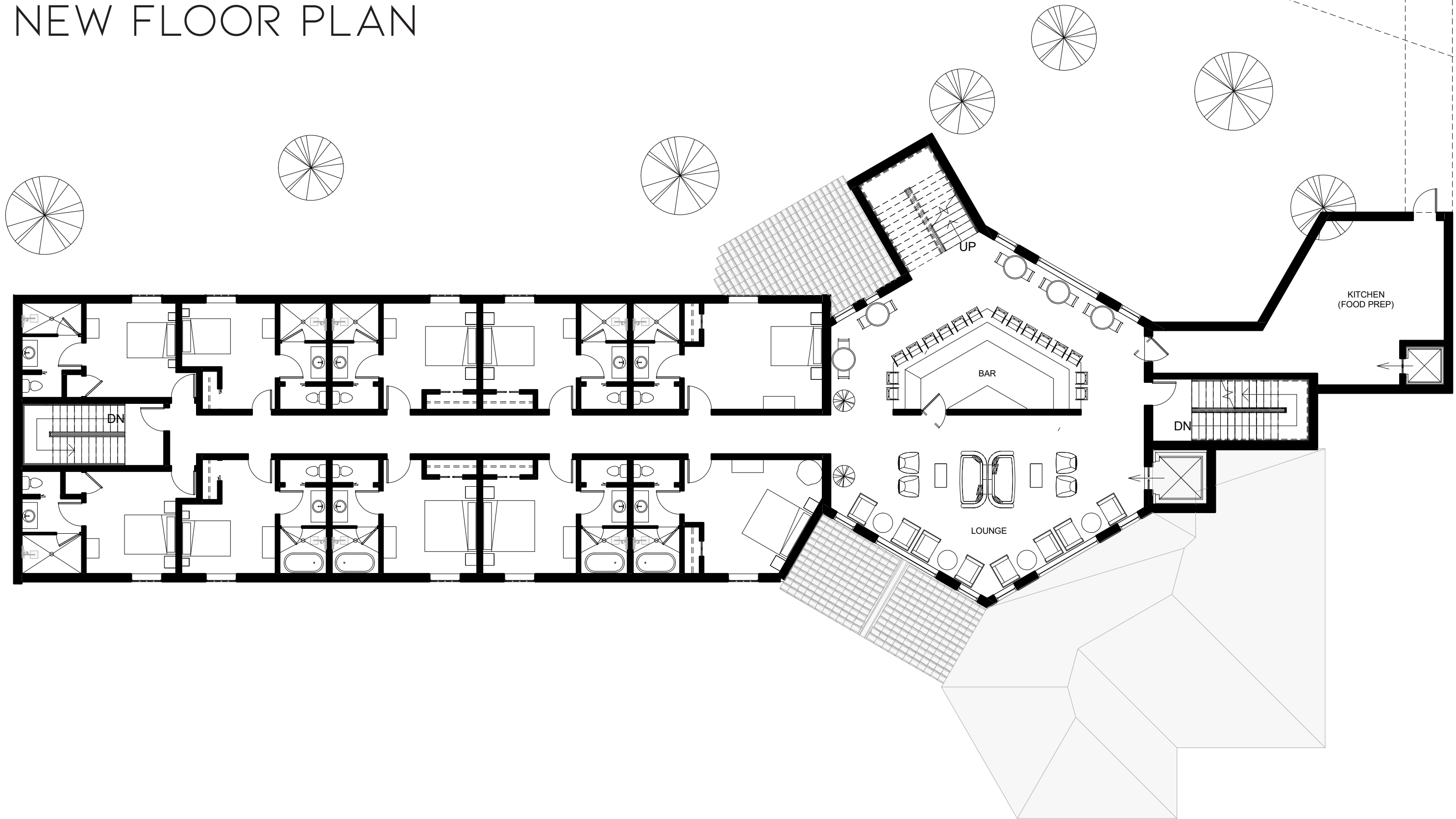

1 LEVEL 3 - FLOOR PLAN
1" = 12'-0"



NEW FLOOR PLAN

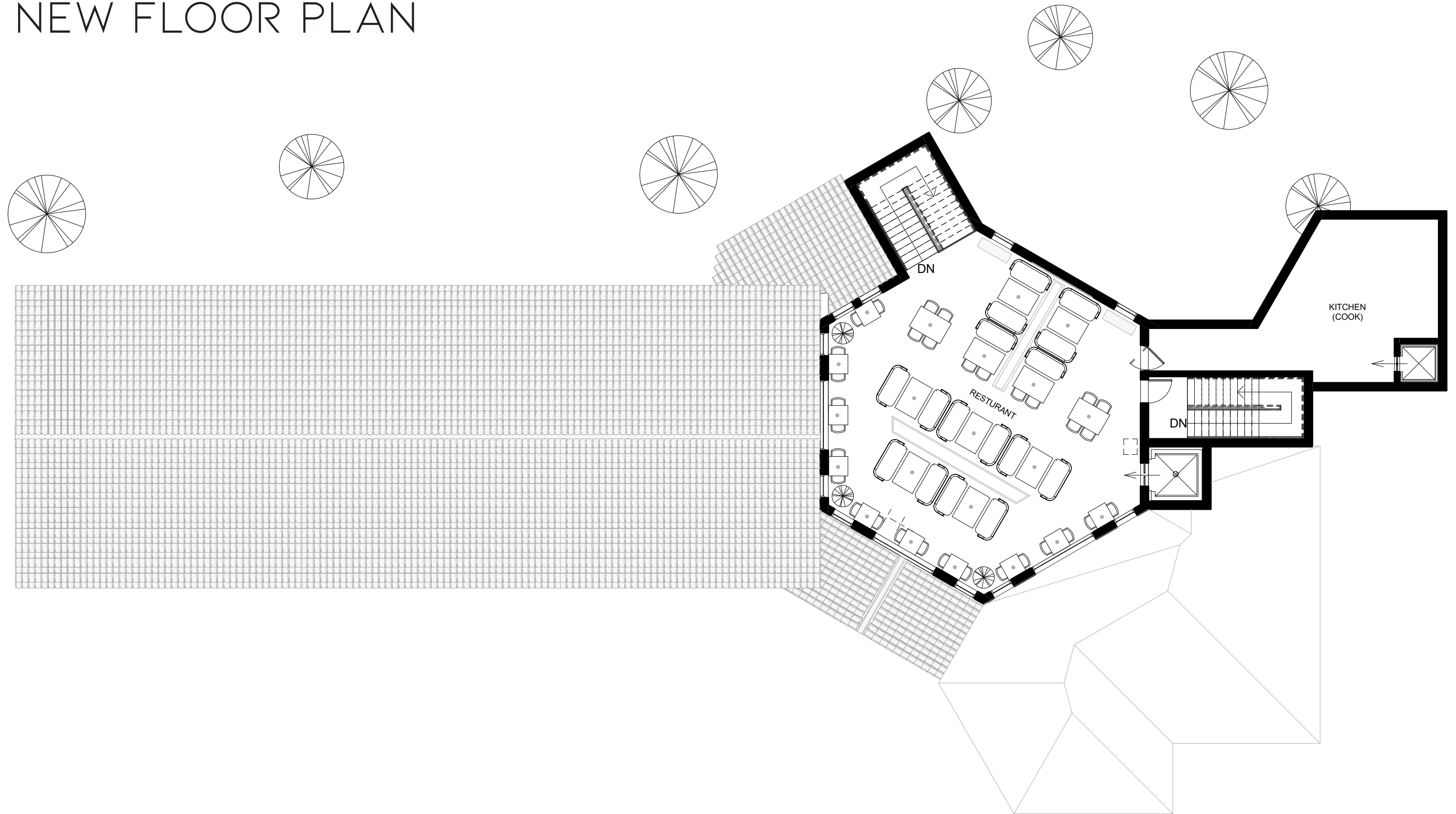

① LEVEL 4 - FLOOR PLAN
1" = 12'-0"



REFLECTED CEILING PLAN

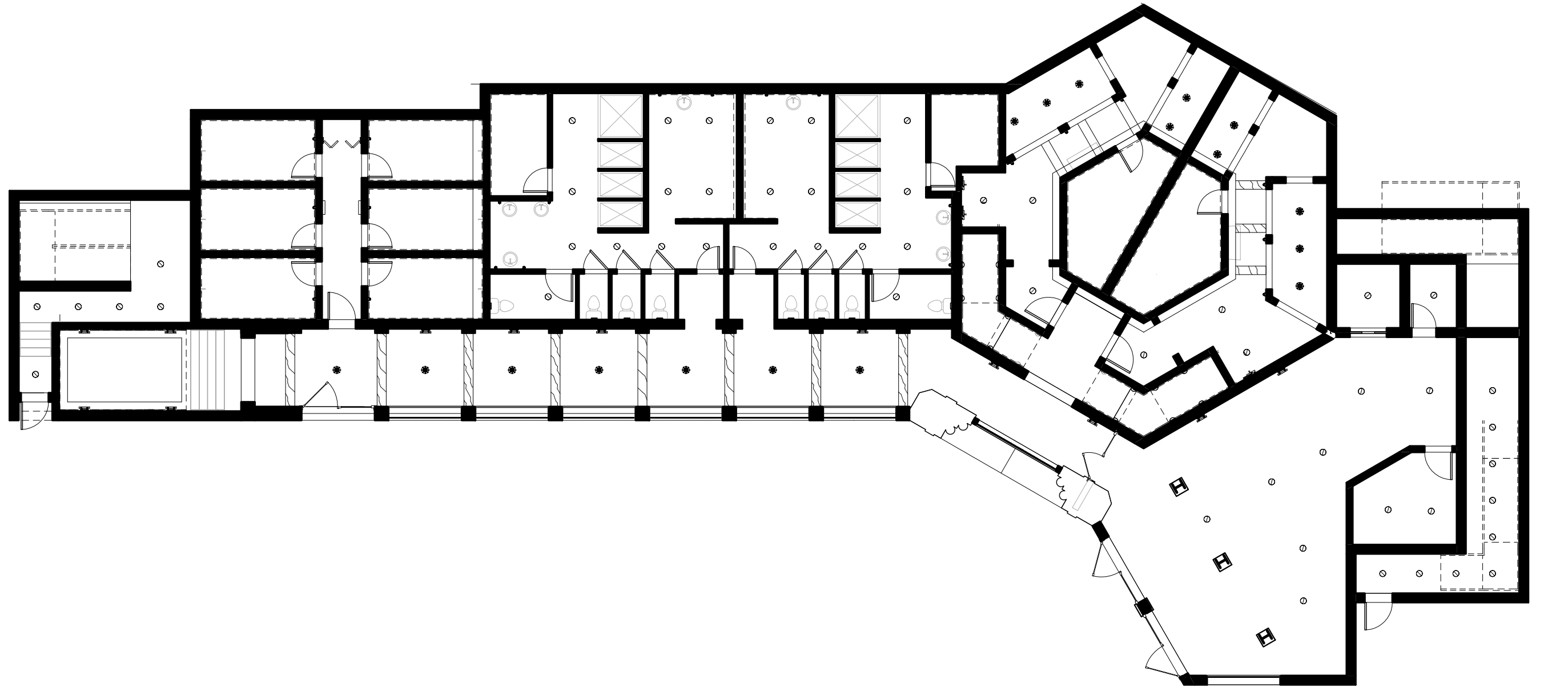

① LEVEL 1 - REFLECTED CEILING PLAN
1" = 12'-0"

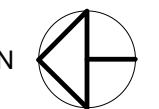

REFLECTED CEILING PLAN

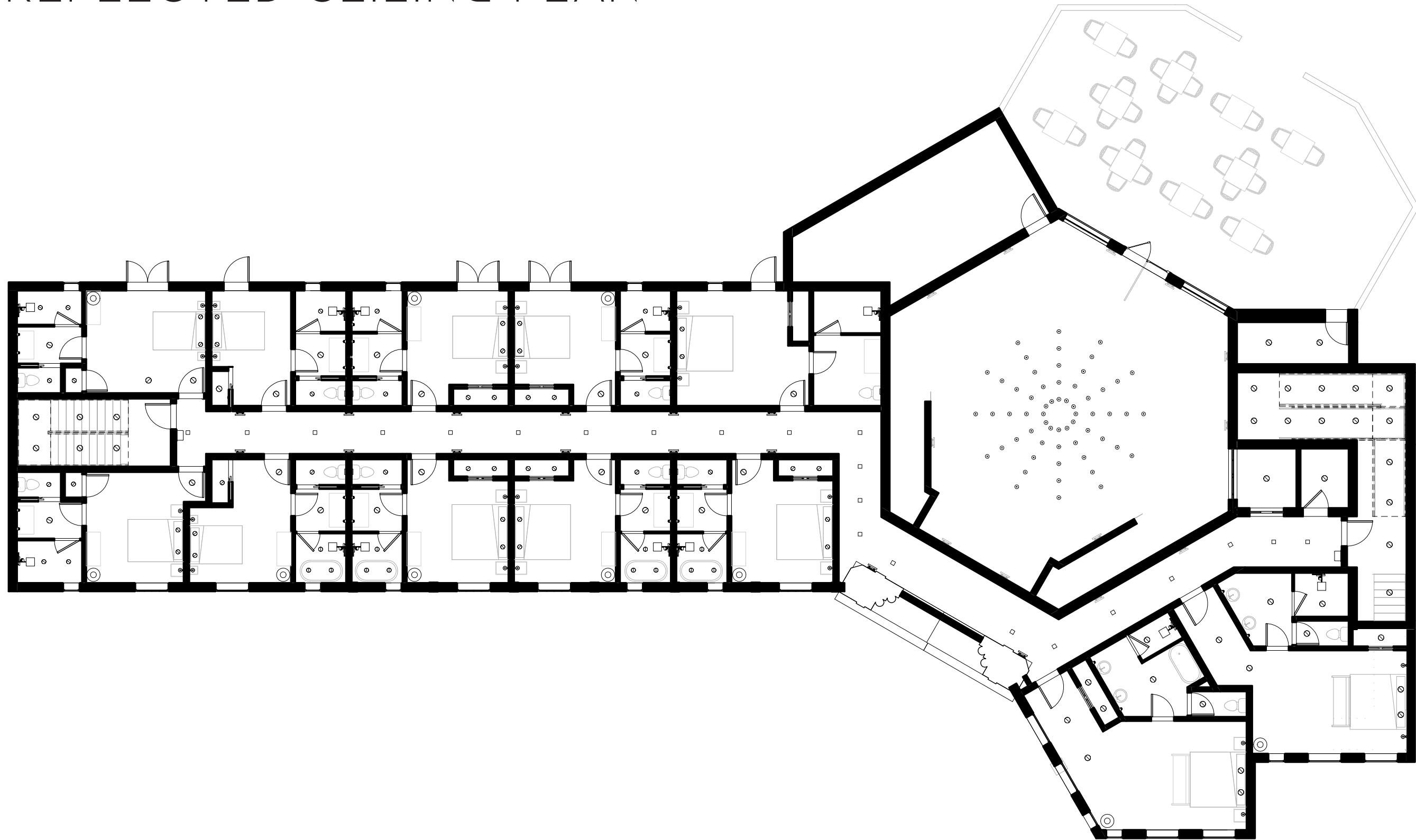

① LEVEL 2- REFLECTED CEILING PLAN
1" = 12'-0"

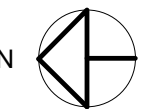

REFLECTED CEILING PLAN

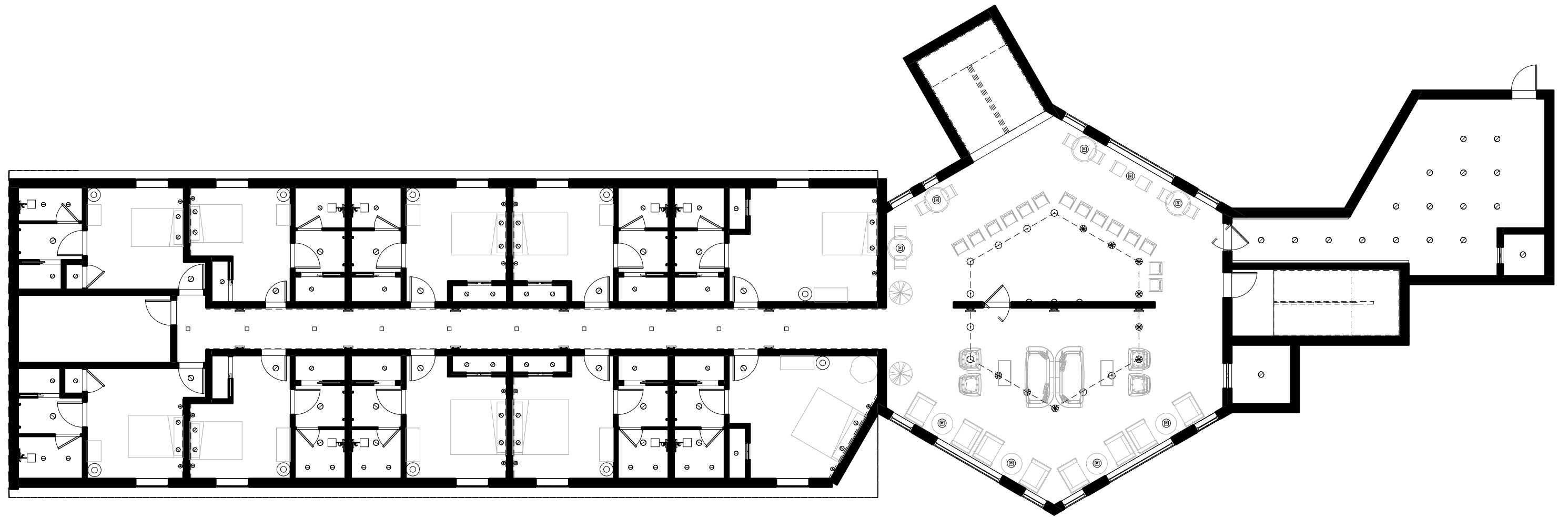

1 LEVEL 3 - REFLECTED CEILING PLAN
1" = 12'-0"

REFLECTED CEILING PLAN

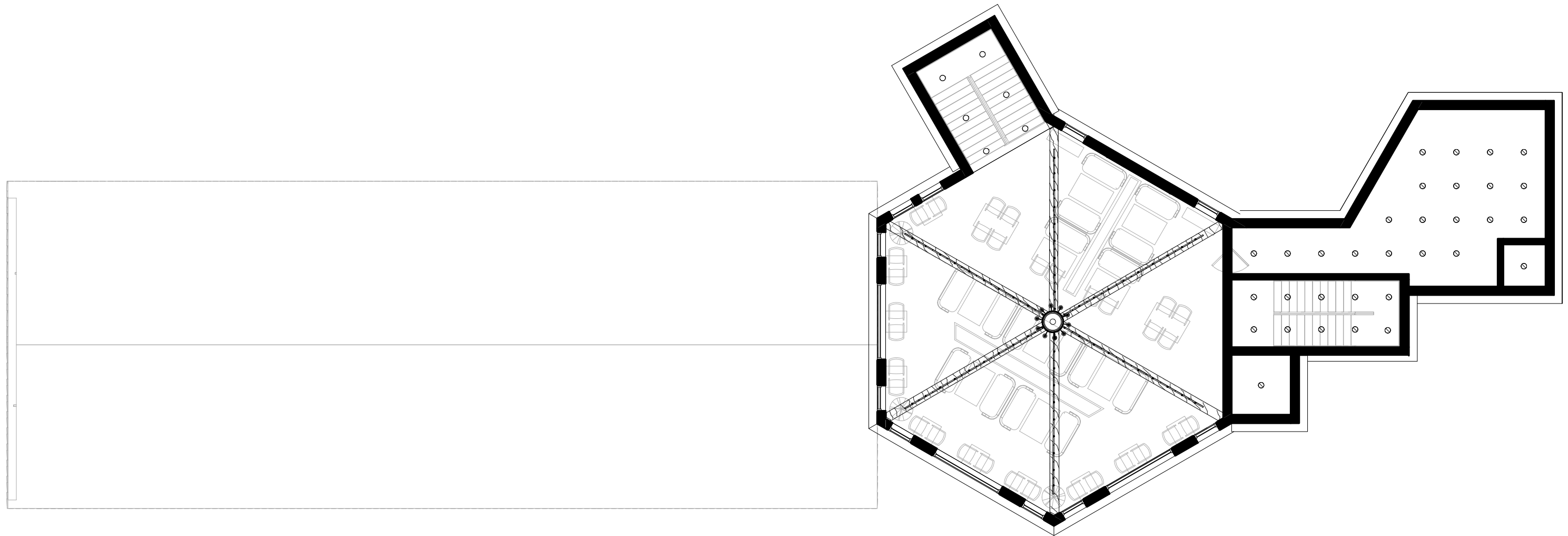

① LEVEL 4 - REFLECTED CEILING PLAN
1" = 12'-0"

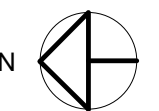
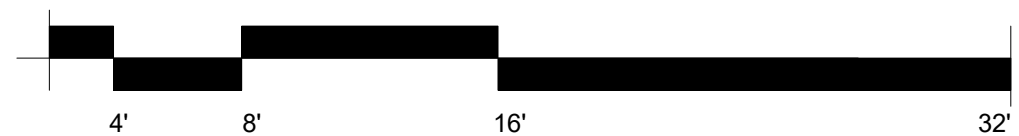

ELEVATION



① EAST ELEVATION
1" = 12'-0"

ELEVATION



① WEST ELEVATION
1" = 12'-0"

ELEVATION



② SOUTH ELEVATION
1" = 12'-0"



① NORTH
1" = 12'-0"

SECTION

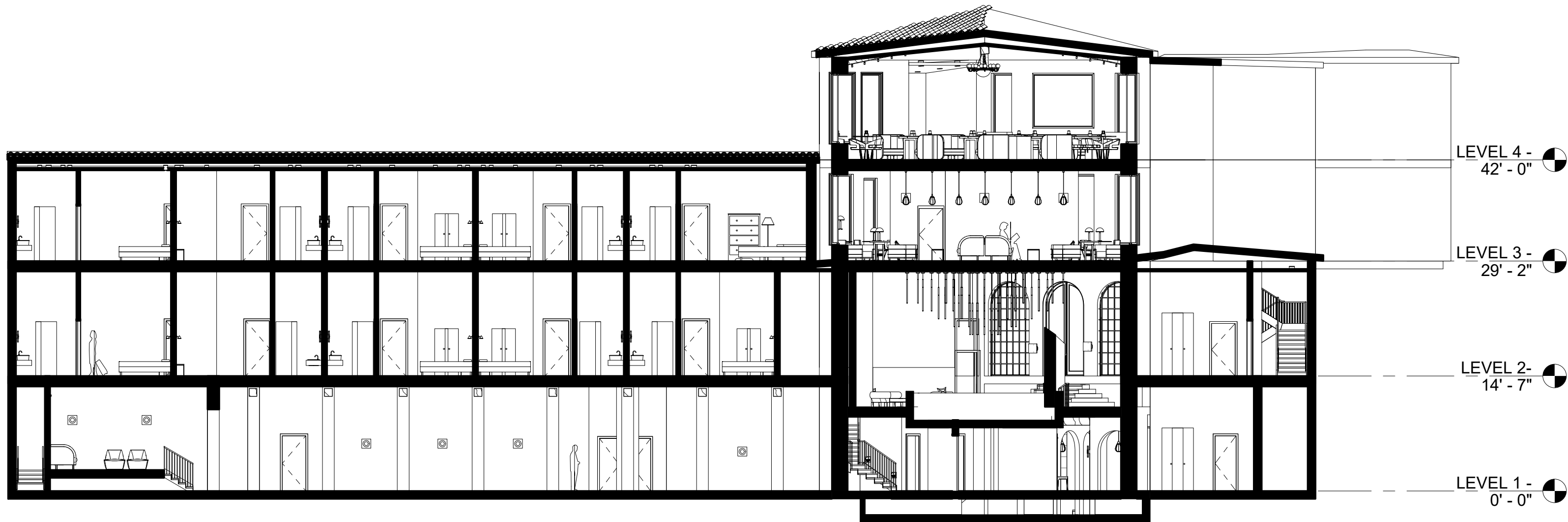

1 Section 1
1" = 12'-0"

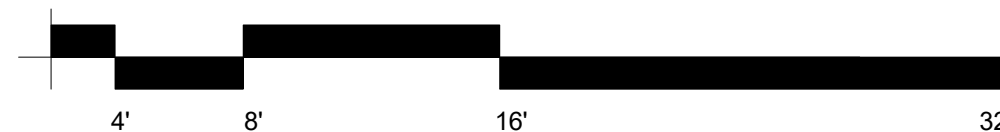

CUSTOM DETAIL

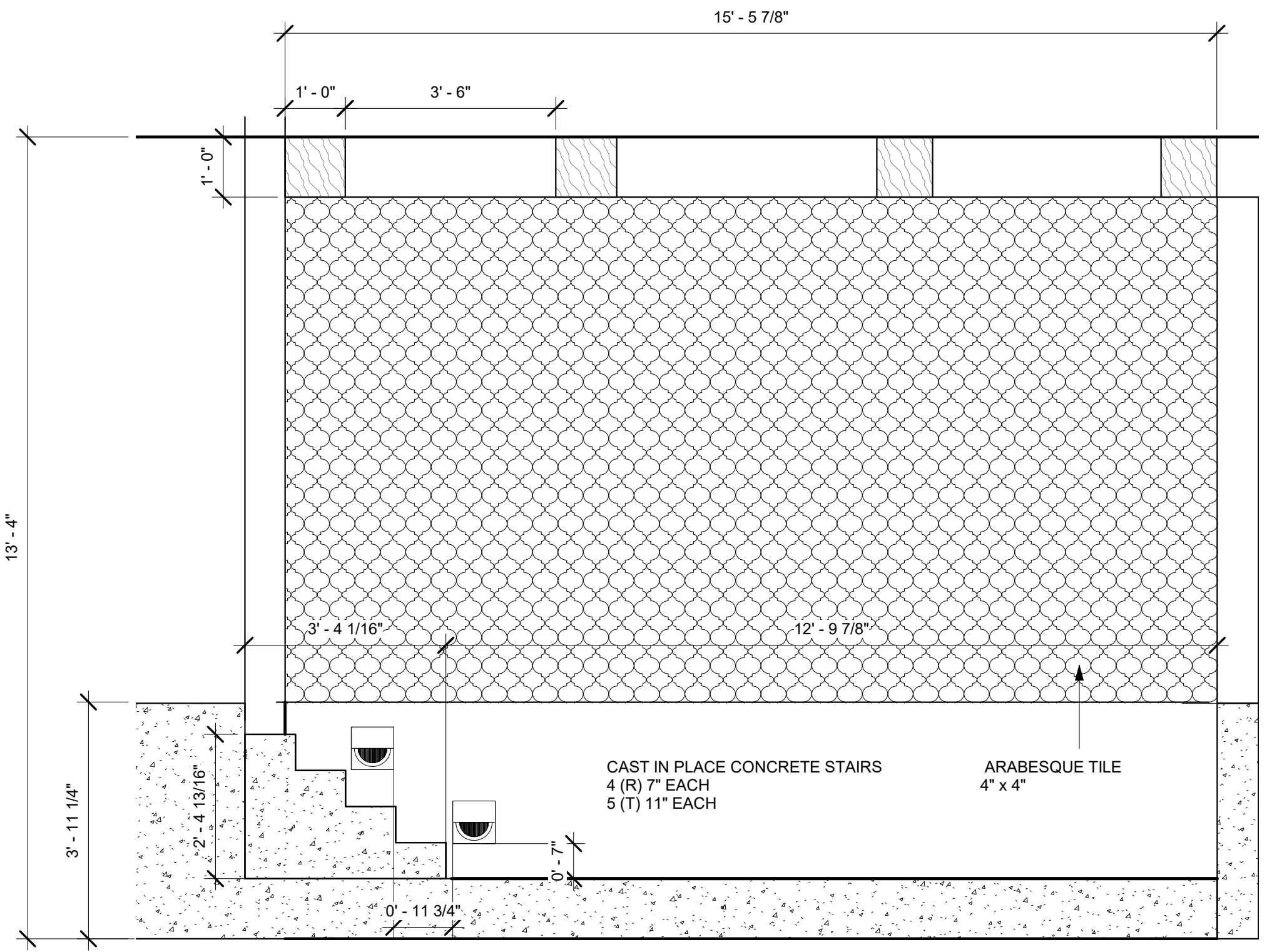
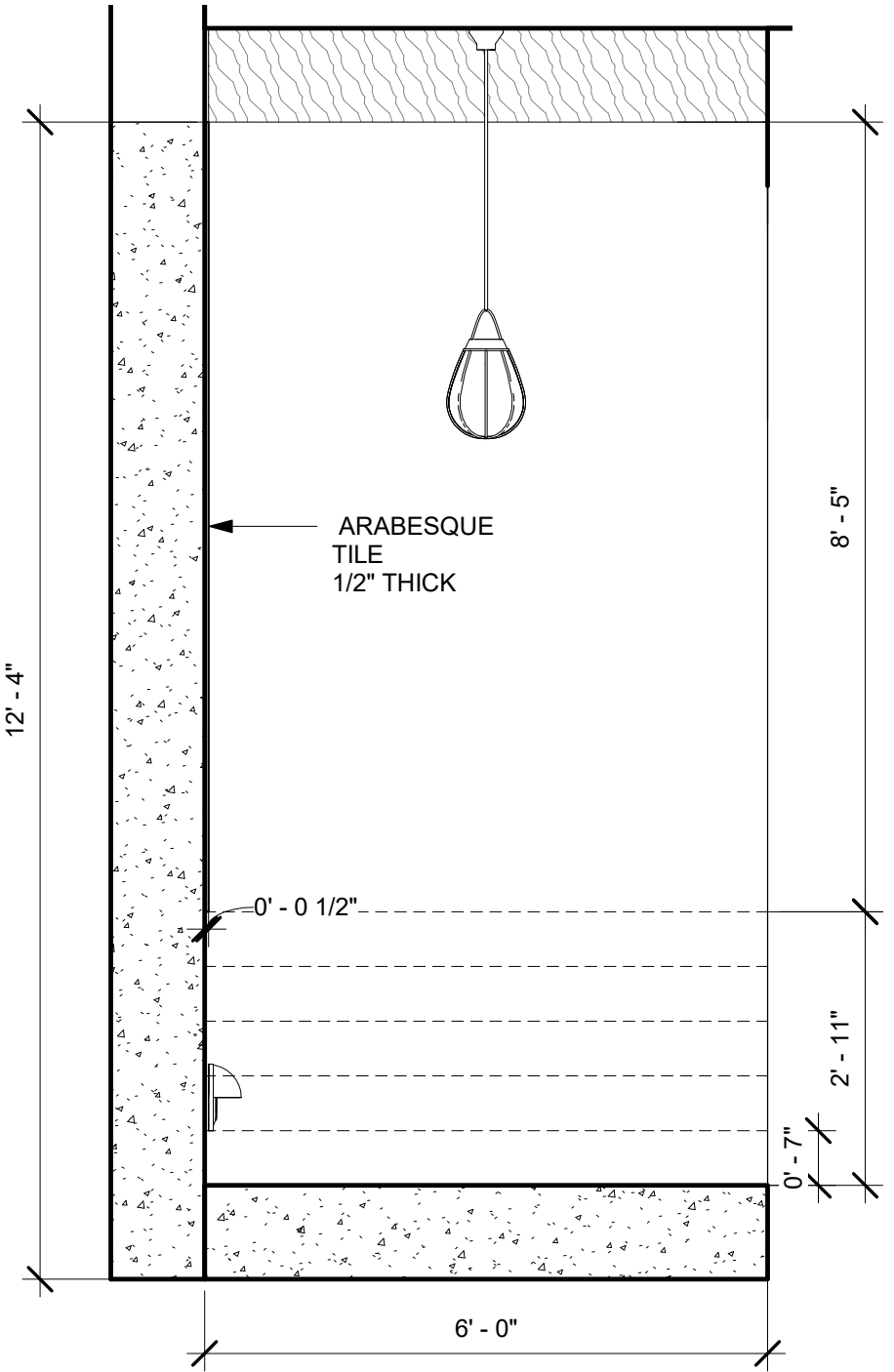

CUSTOM DETAIL

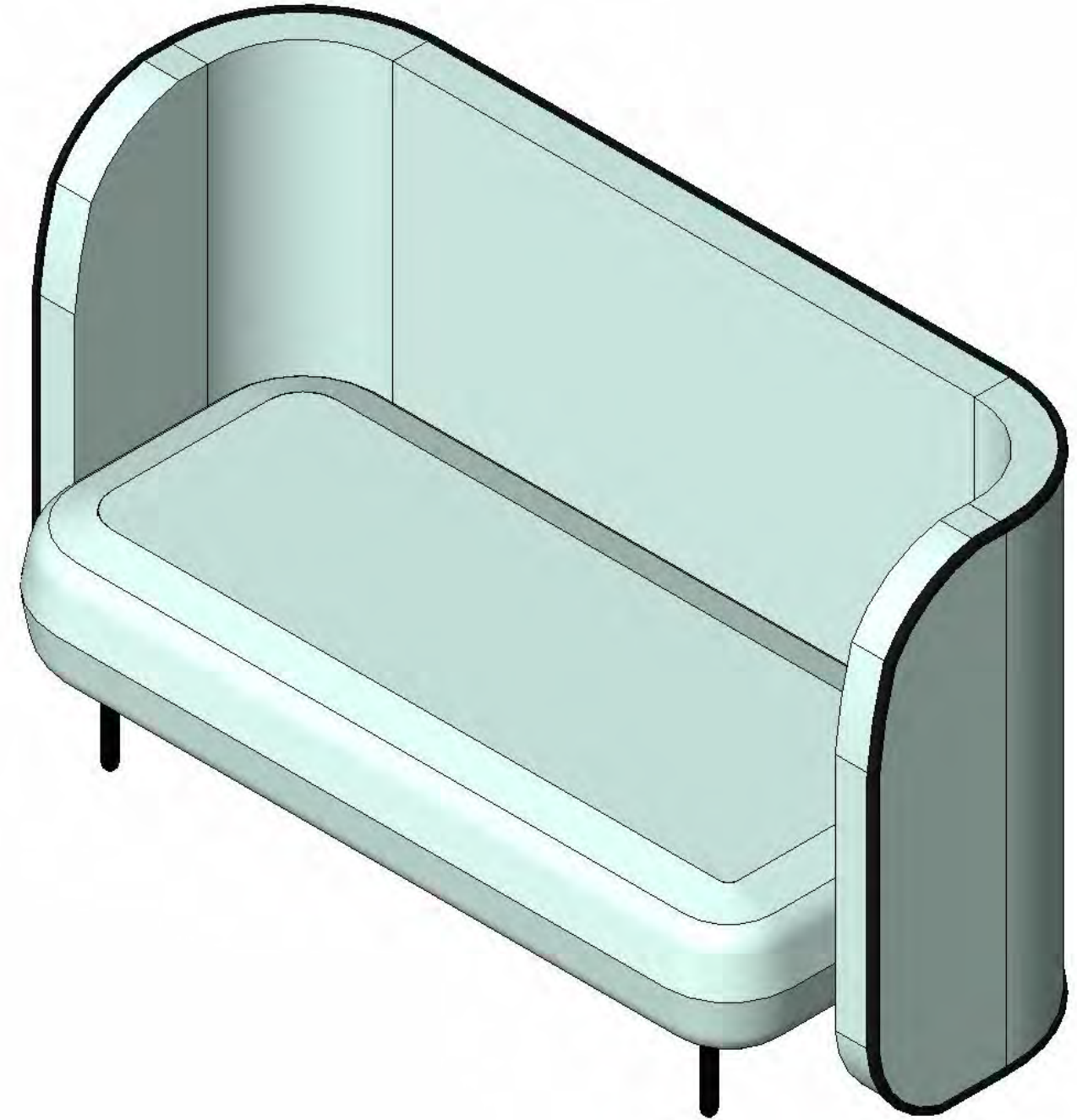
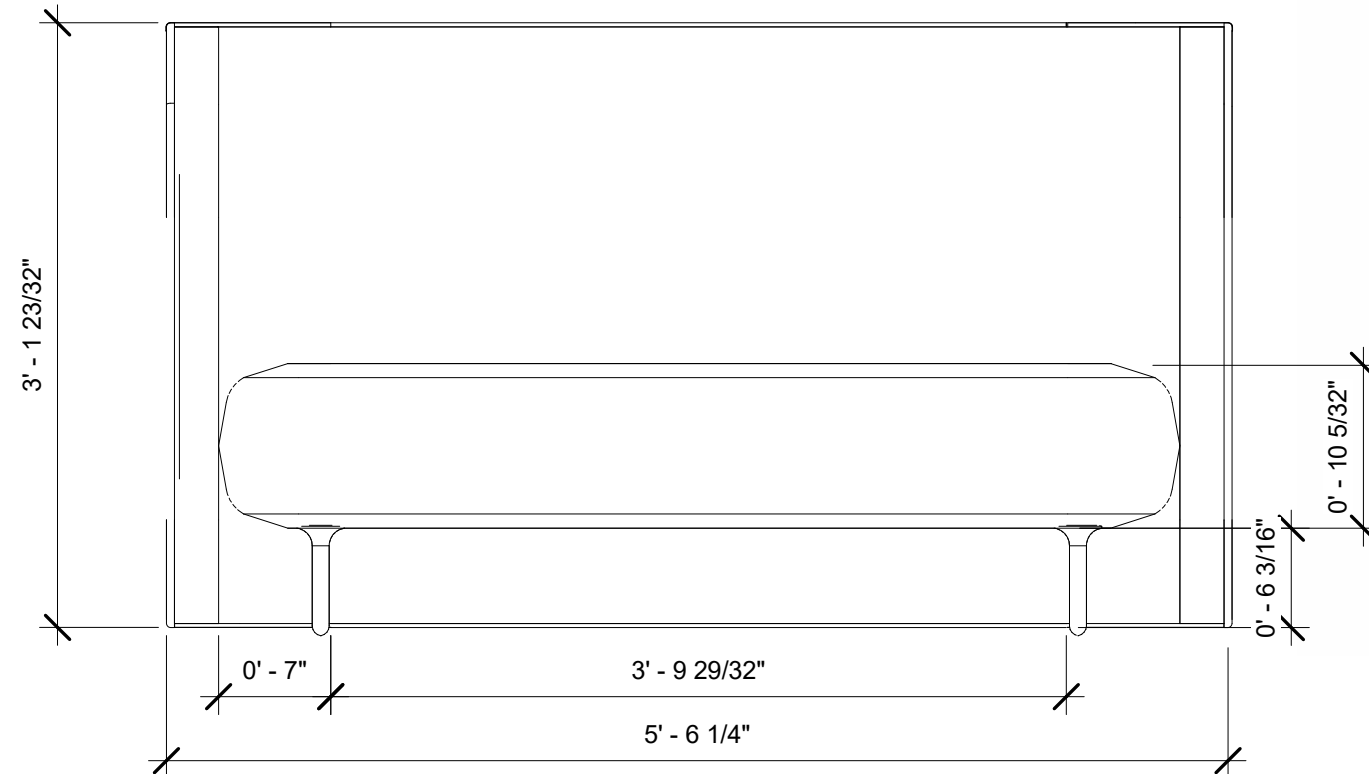
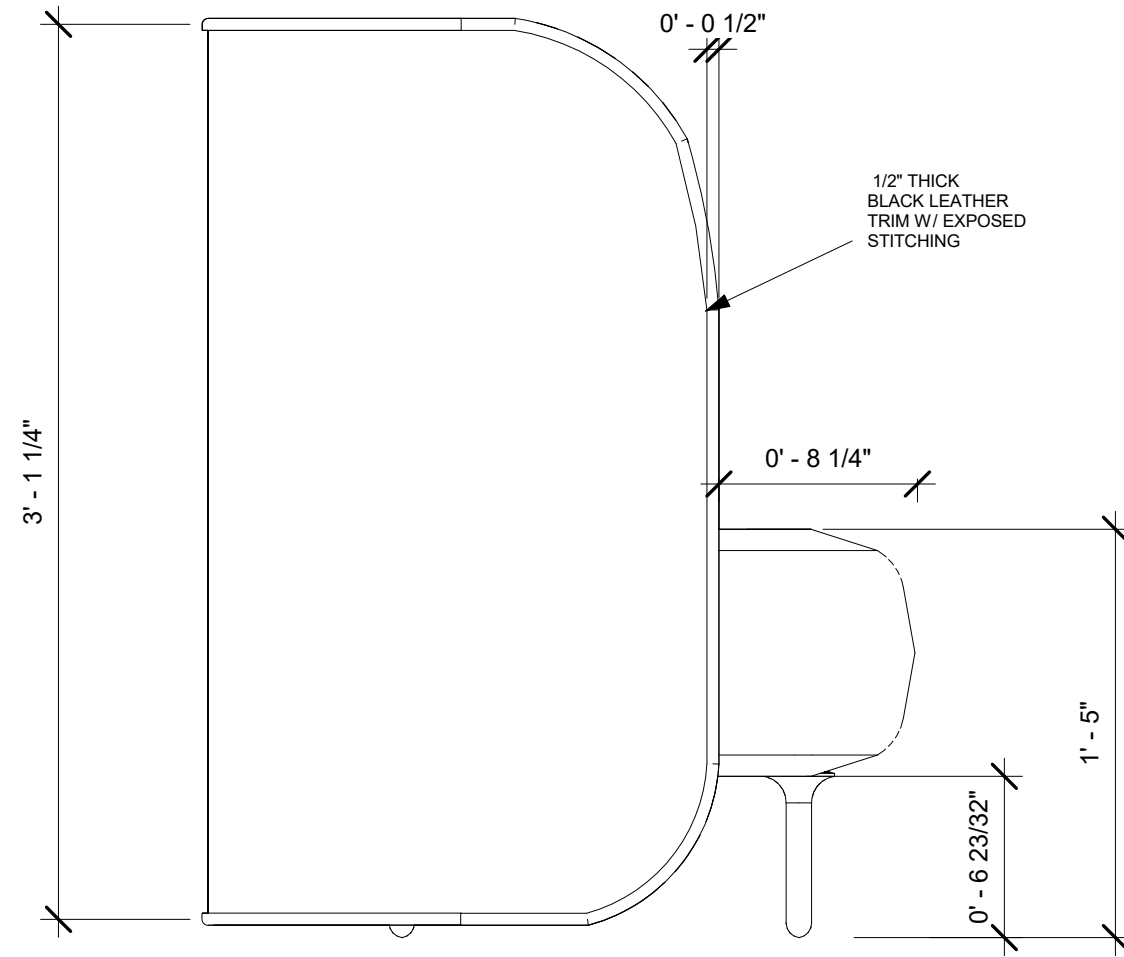

CUSTOM DETAIL

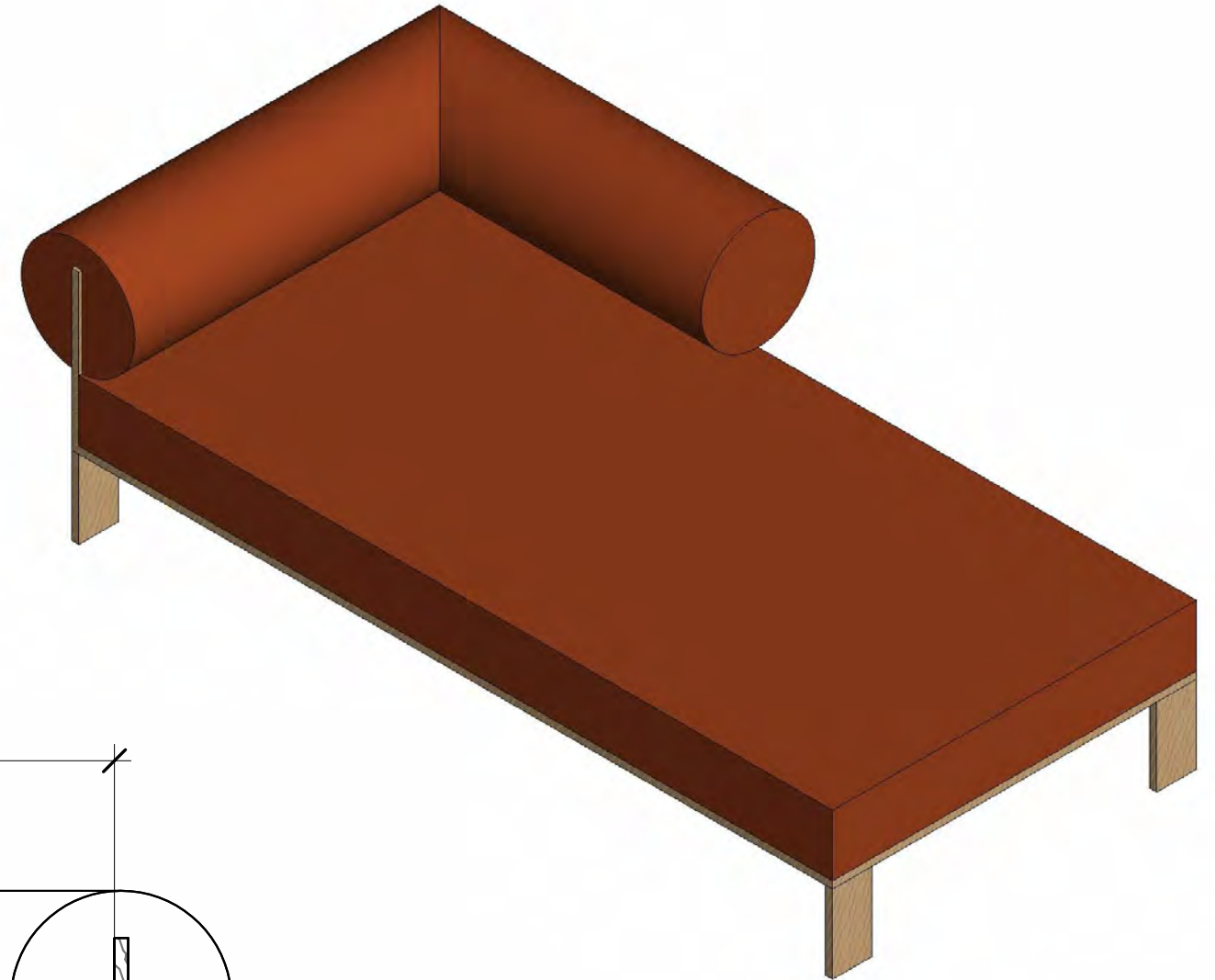
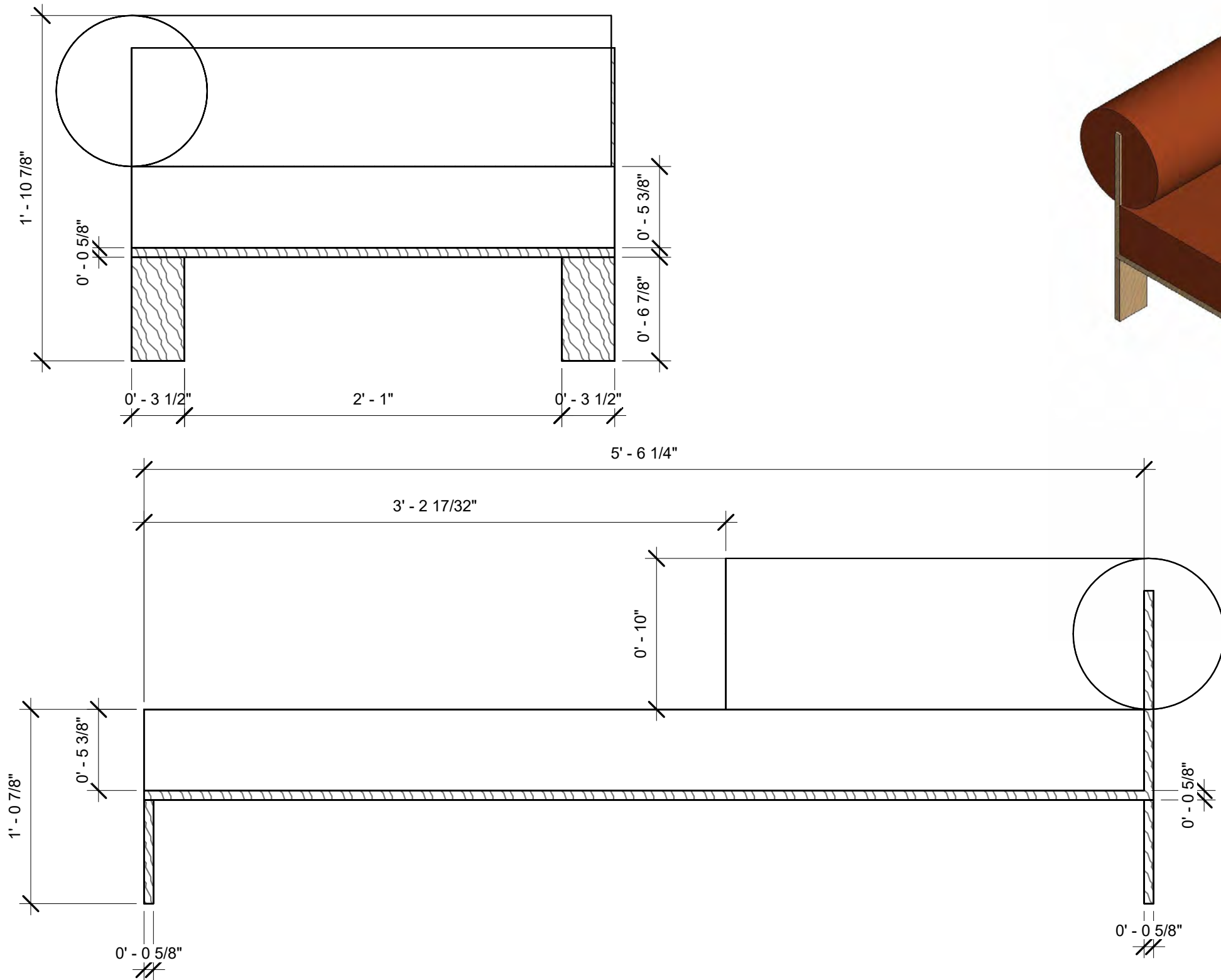

CUSTOM DETAIL

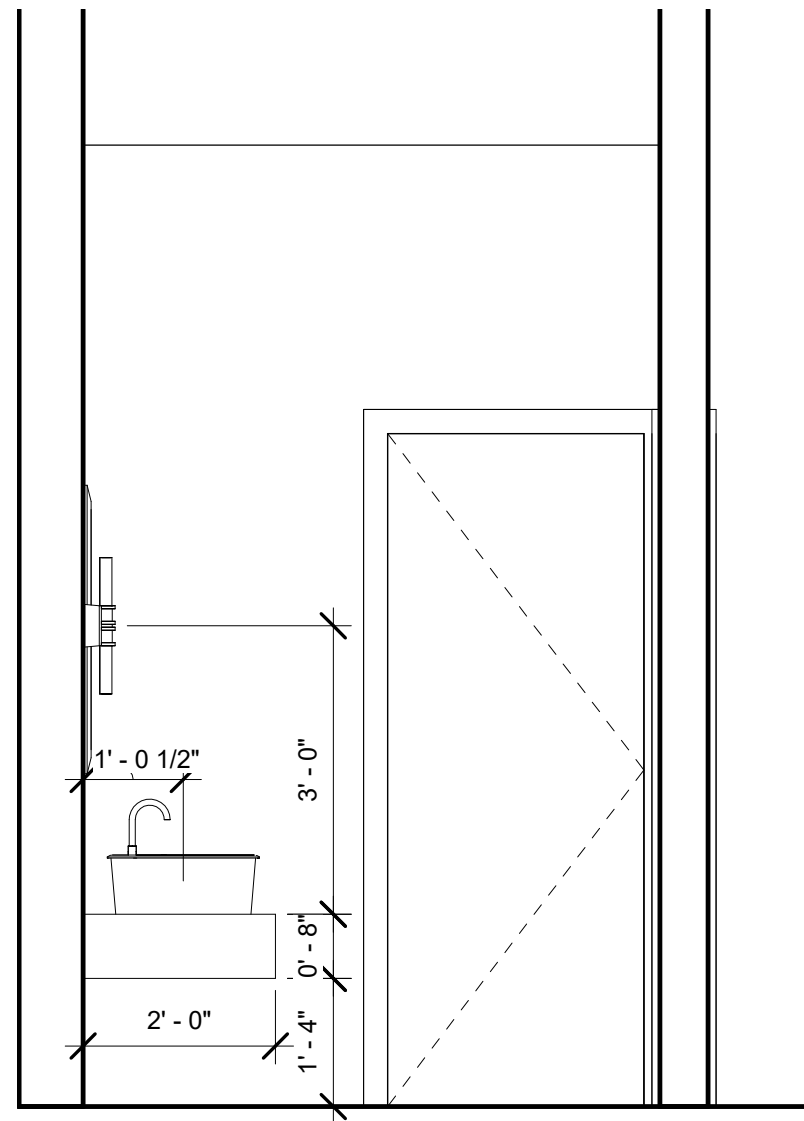
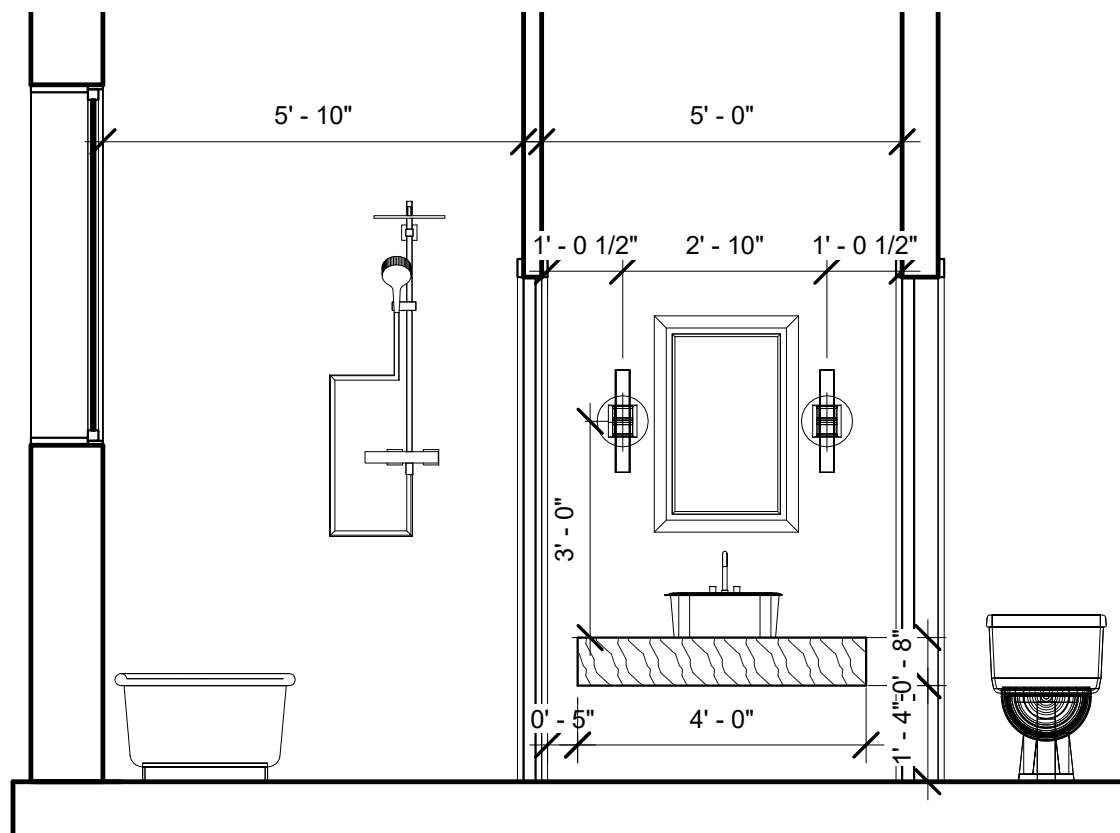

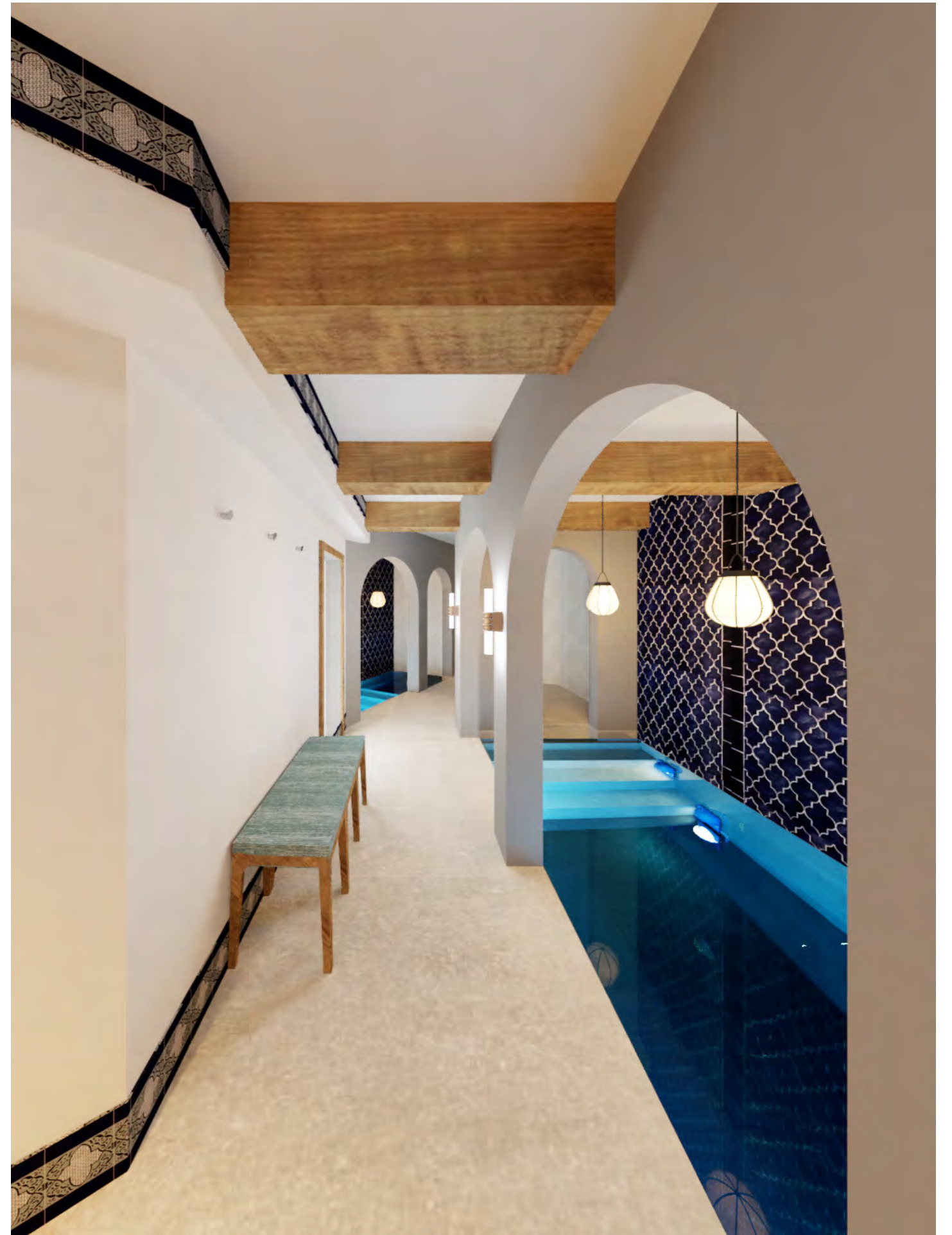





FF&E



MATERIALS

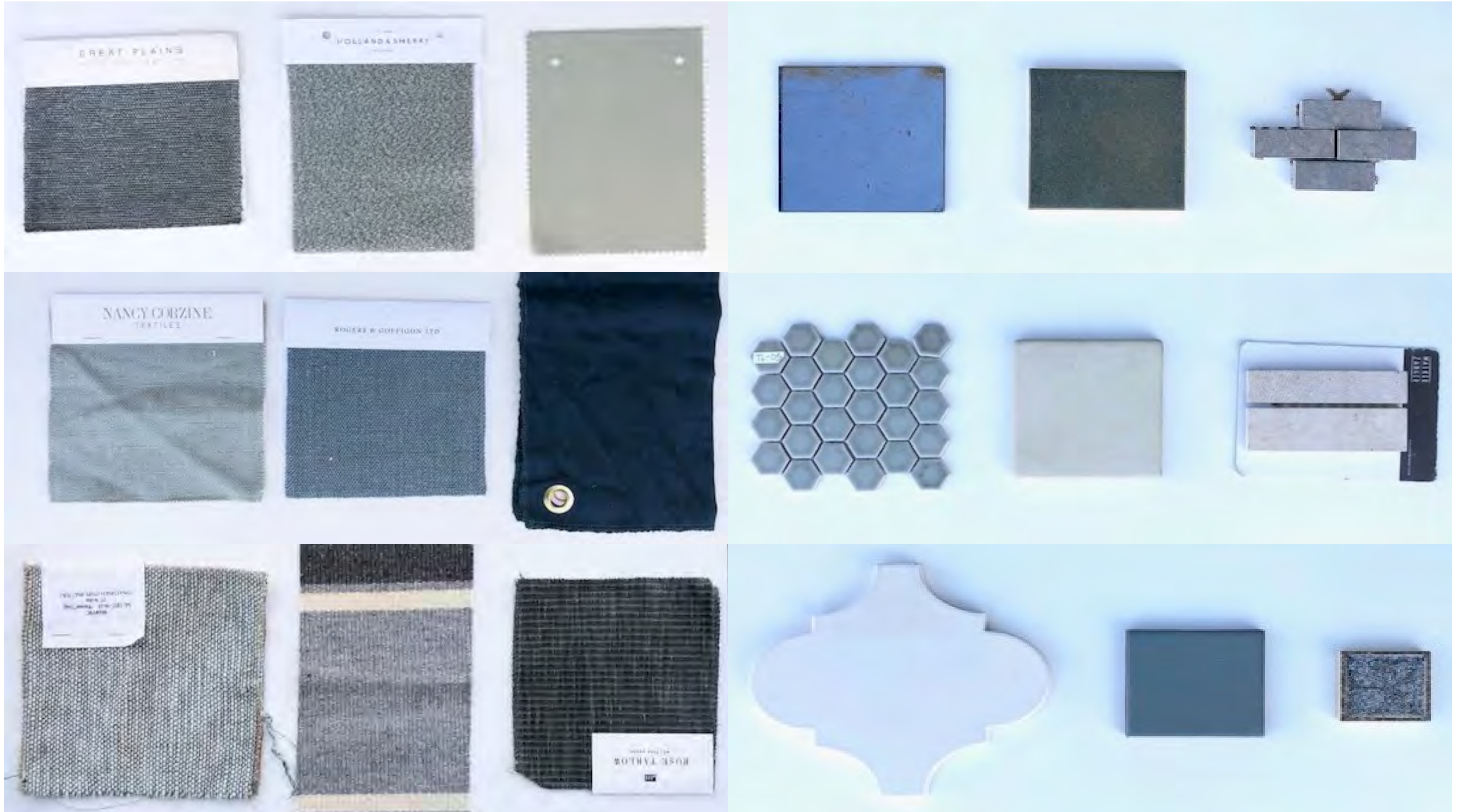

MATERIALS



FURNITURE



FURNITURE



LIGHTING



BIBLIOGRAPHY

WEBSITES:

[HTTP://ARTICLES.LATIMES.COM/2002/MAY/29/ENTERTAINMENT/ET-WELKOS29](http://articles.latimes.com/2002/may/29/entertainment/et-welkos29)

[HTTPS://WWW.EDEN-MEDINA-MARRAKECH.COM](https://www.eden-medina-marrakech.com)

[HTTPS://HUGHSPA.COM](https://hughspa.com)

[HTTPS://WWW.VODASPA.COM](https://www.vodaspa.com)

[HTTP://ZIMAS.LACITY.ORG](http://zimas.lacity.org)

BOOKS:

KOREN, LEONARD. WABI-SABI FOR ARTISTS, DESIGNERS, POETS & PHILOSOPHERS. IMPERFECT PUBLISHING, 2008.

MAEDA, JOHN. THE LAWS OF SIMPLICITY. MIT, 2006.

OTHER:

MICHAEL RUSSEL - CONTRACTOR

PINTERST

